

## Dome loaded section overview

### Regulators

#### Function

Pressure regulators (reducers or controllers) control the outlet pressure over a range of varying inlet pressures and flows. Regulators are sometimes called “Forward Regulators” to limit confusion with Back Pressure Maintaining Valves.

#### Remote control

A small, low flow, spring loaded regulator or proportional valve can be connected to the external vent port of a larger dome loaded regulator. The outlet set pressure of the dome loaded valve is therefore controlled by adjusting the spring loaded regulator.

It is ideal that a spring loaded regulator with down stream release is used.

### Dome Loaded Regulators

#### How does it work

We can divide the valve into three modules of construction.

- Control Module
- Sensing Module
- Metering Module

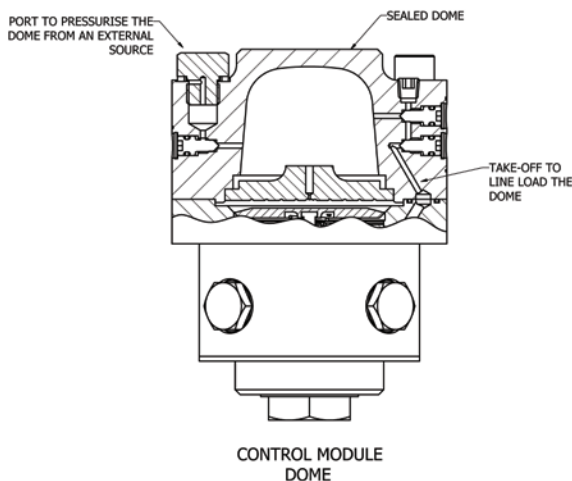

#### Control Module

With Dome Loaded Regulators the down stream pressure is set by increasing or decreasing the pressure in the dome via pressurising the dome with an inert gas. The supply can either come via an external source (e.g. gas bottle) or in the case of inert medias from the line loading. The dome loaded valves are supplied un-charged. Do not use liquid.

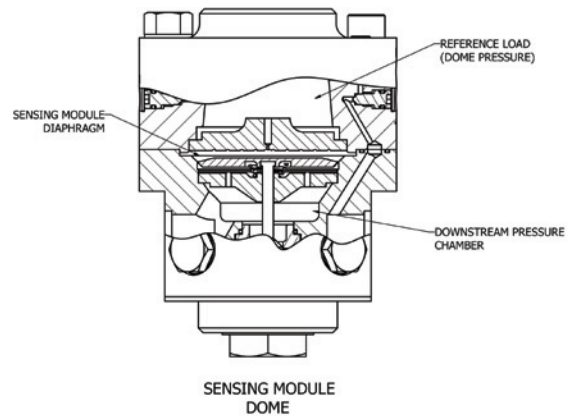

#### Sensing Module

The sensing module compares the down stream pressure on one side of the module to the applied reference load on the other. In matching the forces generated on each face provides the mechanical link to open and close the valve. Thompson Valves use two approaches, they are

- Diaphragm
- Metering

#### Diaphragm—rubber (elastomer), metal

The flexible diaphragm keeps the dome pressure isolated from the outlet side. As the areas on both sides of the diaphragm are the same then the set outlet pressure is about the same as the dome pressure.

## Dome loaded section overview

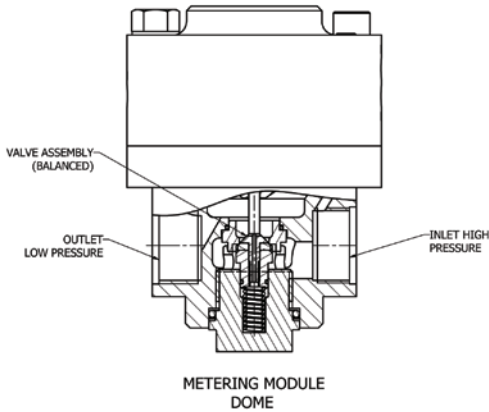

### Metering Module

The “valve” or “poppet” controls the flow of high pressure upstream media into the low pressure (down stream) system. The valve may be balanced providing control, accuracy and repeatability under conditions of decaying up stream pressure or unbalanced which is generally used on low pressure down stream systems requiring high flow.

Unbalanced should not be used with high pressure systems where accurate control is required.

## Back Pressure Maintaining Valves

### Function

Back pressure maintaining valves regulate the inlet pressure and to keep this pressure at a constant flow. This means the valve will open to reduce excessive pressure in the line or close when the pressure drops below a pre-determined setting.

As with a regulator, the operating force can be supplied by a spring or by gas pressure. When the force provided by the inlet pressure acting on the operating area is greater than the operating force (spring or dome pressure), the valve opens allowing fluid to pass from the inlet to the outlet.