

Maxseal Solenoid Operated Valves



ICO2S
1/4" 3/2
PBMR



Typical Applications

- 1/4" 3/2 PUSH BUTTON MANUAL RESET
- Intrinsically Safe
- Pilot Assisted Control Valve
- Hazardous Area Applications

Thompson Valves Ltd

Description

- Model: ICO2S 1/4" 3/2 PBMR
- Pilot Assisted Solenoid Valve
- High Flow
- Max Inlet Pressure 20 bar (290 psi)
- Pilot Pressure 3-7 bar
- Reliable and long life, ideal for a one time installation
- A pilot assisted solenoid operated valve for the control of pneumatic or hydraulic operated equipment

Standard Features

<input type="checkbox"/> Solenoid Materials of Construction	<input type="checkbox"/> Solenoid Pot - Stainless Steel - BFC 316
	<input type="checkbox"/> Top Cover - Stainless Steel- BFC 316
	<input type="checkbox"/> Valve Body & Trim Materials - 316 Stainless Steel
	<input type="checkbox"/> O-Rings Seats & Seals - High Nitrile (NBR)
	<input type="checkbox"/> Coil Insulation - Class H
<input type="checkbox"/> Maximum Inlet Pressure	<input type="checkbox"/> 20 bar (290 psi)
<input type="checkbox"/> Pilot Pressure	<input type="checkbox"/> 3-7 bar
<input type="checkbox"/> Flow Rates	<input type="checkbox"/> $C_v = 0.8$ USgpm for 1 psi Δp
	<input type="checkbox"/> $K_v = 11.52$ l/min for 1 bar Δp
<input type="checkbox"/> Temperature Ratings	<input type="checkbox"/> Media (Min/Max -20°C/90°C) - Ambient (Min/Max 0°C/60°C)
<input type="checkbox"/> Valve Size	<input type="checkbox"/> 1/4" Balanced Poppet Valve
<input type="checkbox"/> Process Connections	<input type="checkbox"/> 1/4" NPT
<input type="checkbox"/> Conduit Connection	<input type="checkbox"/> M20 x 1.5 Conduit Thread
<input type="checkbox"/> Signal Connection	<input type="checkbox"/> 1/4" NPT
<input type="checkbox"/> Media	<input type="checkbox"/> Gas or Air
<input type="checkbox"/> Pilot Media	<input type="checkbox"/> Instrument Air
<input type="checkbox"/> Weight	<input type="checkbox"/> 4.5 kg

Recommended Spares Kits

<input type="checkbox"/> Soft Spares (O-rings, Springs, etc.)	<input type="checkbox"/> Y2H23P01S000000-SS
<input type="checkbox"/> Spare Coil Assembly	<input type="checkbox"/> Please call

Options

<input type="checkbox"/> Process Connections	<input type="checkbox"/> 1/4" BSPP
<input type="checkbox"/> Conduit Connection	<input type="checkbox"/> 1/2" NPT
<input type="checkbox"/> Signal Connections	<input type="checkbox"/> 1/4" BSPP
<input type="checkbox"/> Product Lead Time	<input type="checkbox"/> Y2H23PA1SA10300 - 4 weeks

Other variations: Please call for possible delivery dates

Technical Specification

Pressures

Test (Proof) Pressure	<input type="checkbox"/> 30 bar (435 psi)
Maximum Inlet Pressure	<input type="checkbox"/> 20 bar (290 psi)
Pilot Test (Proof) Pressure	<input type="checkbox"/> 12 bar (174 psi)
Pilot Pressure	<input type="checkbox"/> 3-7 bar (43-102 psi)
ATEX Classification	<input type="checkbox"/> Complies with ATEX Directive 94/9/EC
ATEX Certificate	<input type="checkbox"/> SIRA 00ATEX2113
Certification 	<input type="checkbox"/> II 1G <input type="checkbox"/> Ex ia IIC T6 (T _a = -40°C to + 64°C)

Intrinsically Safe Circuit

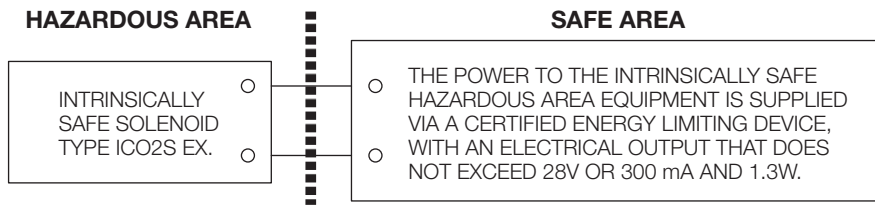

Ingress Protection	<input type="checkbox"/> IP66/X8 to BS EN 6052:1992, NEMA 4X
Voltage Surge Protection	<input type="checkbox"/> Surge Suppression Diodes
Coil Insulation	<input type="checkbox"/> Class H

Performance

Pull-in Voltage	<input type="checkbox"/> 87.5% of Nominal
Response Times	<input type="checkbox"/> Pull-In <150 ms
	<input type="checkbox"/> Drop-Out <80 ms
Electromagnetic Compatibility (EMC)	<input type="checkbox"/> EN50081-1 EN50082-1 EN61000-4 parts 2,4,5

Valve Symbol

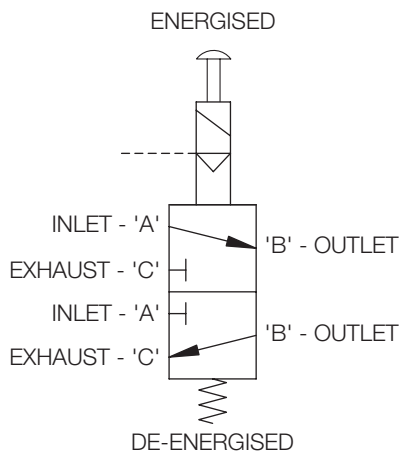

VALVE SYMBOL FOR
ENERGISE TO OPEN
(DE-ENERGISED TO CLOSE)
(NORMALLY CLOSED)

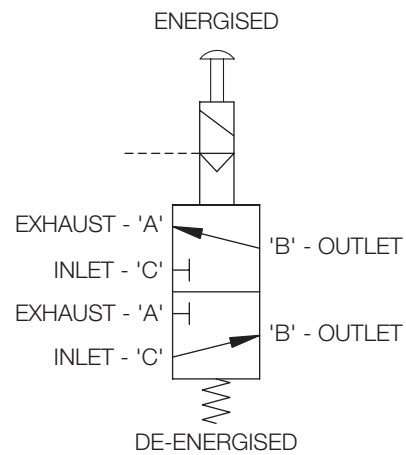

VALVE SYMBOL FOR
ENERGISE TO CLOSE
(DE-ENERGISED TO OPEN)
(NORMALLY OPEN)

Ordering Information

Model	Seat/Seal Materials	Operating Pressure	Port Config.	Operation	Process Conn.	Protection / Coil Housing	Conduit / Sig. Conn.	Voltage/ Signal	Body/Trim Materials	Options
Y2	H	2	3	P	A1	S	A	1	03	00
ICO2S	H High Nitrile	0-20 barg (290 psi)	3/2 UNIVERSAL	PUSH BUTTON MANUAL RESET	A1 1/4" NPT	Ex ia IIC T6	A M20 ISO 1/4" NPT	24V DC / 3-7 barg	316SS / 316SS	None
							B M20 ISO 1/4" BSPP			
	V Viton®				D 1/2" NPT 1/4" NPT					
					E 1/2" NPT 1/4" BSPP					

Ordering Example

Y2	V	2	3	P	E1	S	B	1	03	00
ICO2S	V Viton®	0-20 barg (290 psi)	3/2 UNI	PBMR	1/4" BSPP	Ex ia IIC T6	M20 ISO 1/4" BSPP	24V DC / 3-7 barg	316SS / 316SS	None

Power Consumption (At Nominal)

DC Standard	
24V DC	0.5W

Profile and Dimensions mm

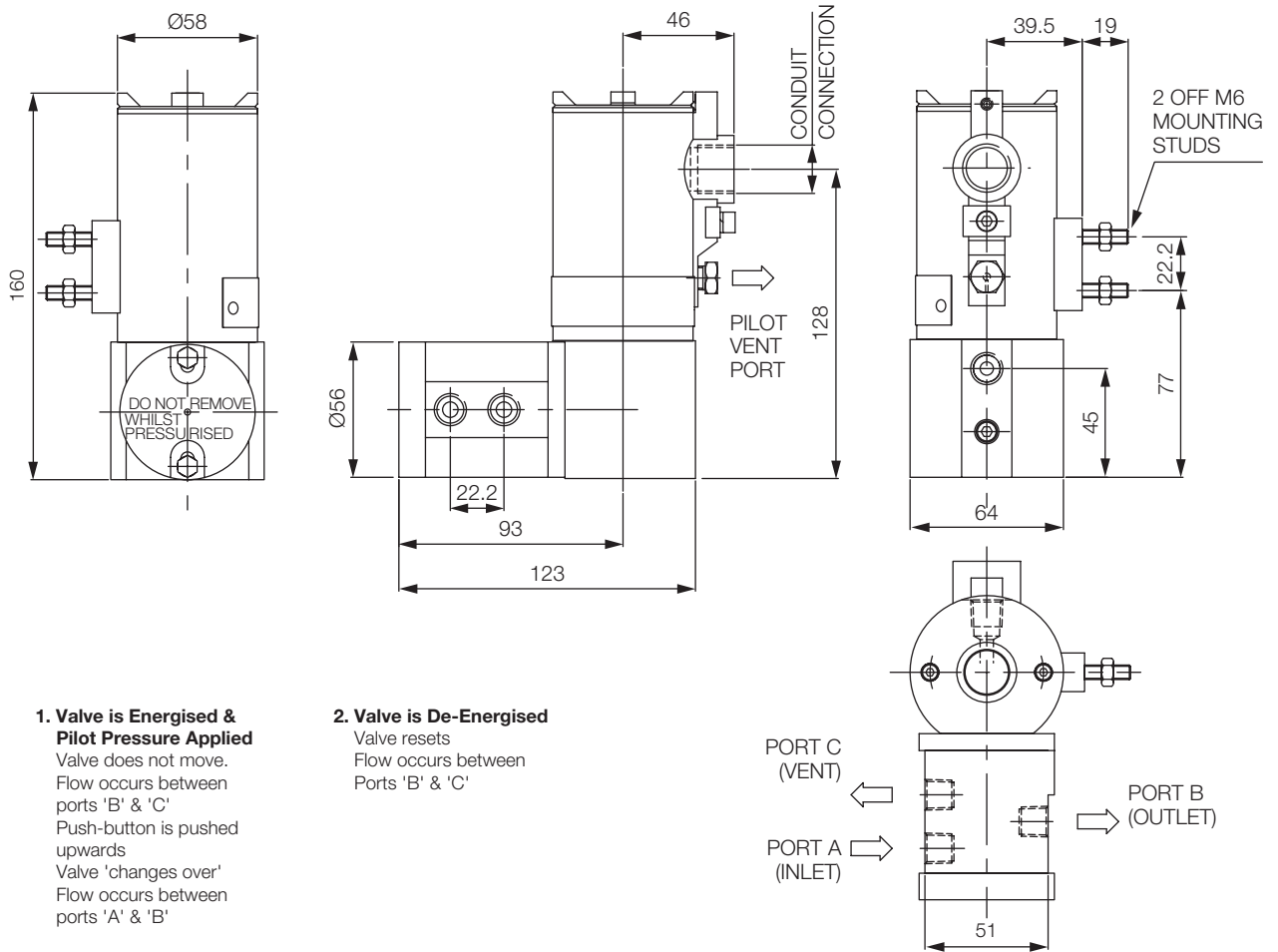

Thompson Valves reserves the right to amend product specifications or designs without notice. Information is given in good faith and no liability can be accepted for error or omission. Viton® is a registered trademark of DuPont Performance Elastomers.