

Maxseal Solenoid Operated Valves



ICO4S
1/2" 2/2
AUTO



Typical Applications

- 1/2" 2/2 ENERGISE TO OPEN - AUTOMATIC
- 1/2" 2/2 ENERGISE TO CLOSE - AUTOMATIC
- Actuator Control
- Direct Acting Shut Off Valve
- Oil & Gas Applications
- Turbine Fuel Control

Thompson Valves Ltd

Description

- Model: ICO4S 1/2" 2/2 EO & EC AUTO
- Direct Acting Solenoid Valve
- Low Pressure, High Flow
- Max Inlet Pressure 20 bar (290 psi)
- Reliable and long life, ideal for a one time installation
- Control of pneumatic or hydraulic operated equipment

Standard Features	<input type="checkbox"/> ICO4S 1/2" 2/2 Auto
Solenoid Materials of Construction	<input type="checkbox"/> Solenoid Pot - Stainless Steel - BFC 316
	<input type="checkbox"/> Top Cover - Stainless Steel- BFC 316
	<input type="checkbox"/> Valve Body & Trim Materials - 316 Stainless Steel
	<input type="checkbox"/> O-Rings Seats & Seals - High Nitrile (NBR)
	<input type="checkbox"/> Coil Insulation - Class H
Maximum Inlet Pressure	<input type="checkbox"/> 20 Bar (290 PSI)
Flow Rates	<input type="checkbox"/> $C_v = 4.2$ USgpm for 1 psi Δp
	<input type="checkbox"/> $K_v = 46$ l/min for 1 bar Δp
Temperature Ratings	<input type="checkbox"/> Media (Min/Max -20°C/90°C) - Ambient (Min/Max 0°C/60°C)
Valve Size	<input type="checkbox"/> 1/2" Balanced Poppet Valve
Process Connections	<input type="checkbox"/> 1/2" NPT
Conduit Connection	<input type="checkbox"/> M20 x 1.5 Conduit Thread
Media	<input type="checkbox"/> Liquid & Gases
Weight	<input type="checkbox"/> 6.0 Kg

Recommended Spares Kits		
Soft Spares (O-rings, Springs etc)	<input type="checkbox"/> Standard (Viton® & High Nitrile)	Y123A030000-SS
	<input type="checkbox"/> Low Temperature valves	See Valve Data Sheet
Spare Coil Assembly	<input type="checkbox"/> Standard 24V DC (15.1 Watts)	Y123A0301B0
	<input type="checkbox"/> Other Variations	See Valve Data Sheet

Options	
Valve Body & Trim Materials	<input type="checkbox"/> Aluminium Bronze - Sea Water Applications
	<input type="checkbox"/> Titanium - Extreme Service Applications
Low Temperature Options	<input type="checkbox"/> O-Rings - Low Nitrile/Fluorosilicone (Min Med/Amb -40°C/-40°C)
High Temperature Options	<input type="checkbox"/> High Temperature Spacer (Max Med/Amb 120°C/60°C)
	Please Call for Dimensions
Process Connections	<input type="checkbox"/> Thread - 1/2" BSPP
Conduit Connection	<input type="checkbox"/> 1/2" NPT
Product lead time	<input type="checkbox"/> Y121AA3H1BS - 2 WEEKS (SUBJECT TO QUANTITY)
	<input type="checkbox"/> Y122AA3H1BS - 2 WEEKS (SUBJECT TO QUANTITY)
	<input type="checkbox"/> Other Variations - Please call for possible delivery dates

Technical Specification

Pressures	
Test (Proof) Pressure	<input type="checkbox"/> 30 bar (435 PSI)
Maximum Inlet Pressure	<input type="checkbox"/> 20 Bar (290 PSI)
ATEX Classification	
ATEX Certificate	<input type="checkbox"/> Complies with ATEX Directive 94/9/EC
ATEX Certificate	<input type="checkbox"/> SIRA 00ATEX1147
Certification	
	<input type="checkbox"/> II 2G
	<input type="checkbox"/> EExd IIC T6 (T _a = -60°C to + 48°C) or
	<input type="checkbox"/> EExd IIC T4 (T _a = -60°C to + 90°C)
IECEX	
	<input type="checkbox"/> IECEX BAS 04.0019
	<input type="checkbox"/> EExd IIC T6 (T _a = -40°C to + 60°C) or
	<input type="checkbox"/> EExd IIC T4 (T _a = -40°C to + 90°C)
GOST 'K'	
	<input type="checkbox"/> EExd IIC T6 (T _a = -40°C to + 60°C)
GOST 'R'	
	<input type="checkbox"/> EExd IIC T6 (T _a = -40°C to + 60°C)
Safety Integrity Level	
	<input type="checkbox"/> Suitable for SIL 3 Application in Simplex Mode
	<input type="checkbox"/> Suitable for SIL 4 Application in Duplex Mode
Ingress Protection	
	<input type="checkbox"/> IP66/X8, NEMA 4X
Voltage Surge Protection	
	<input type="checkbox"/> Surge Suppression Diodes
Coil Insulation	
	<input type="checkbox"/> Class H
Performance	
Pull-in Voltage	<input type="checkbox"/> 87.5% of Nominal
Response Times	
	<input type="checkbox"/> Pull-In <150ms
	<input type="checkbox"/> Drop-Out <80ms
Electromagnetic Compability (EMC)	
	<input type="checkbox"/> EN50081-2/82-1

Valve Symbol

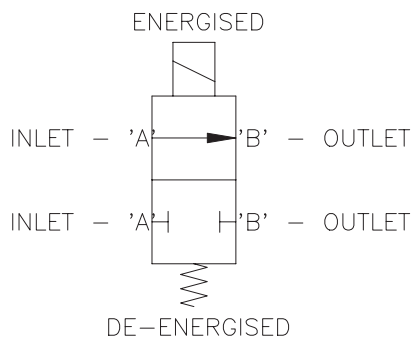

VALVE SYMBOL FOR
ENERGISE TO OPEN
(NORMALLY CLOSED)
20 BAR MAX WORKING
PRESSURE

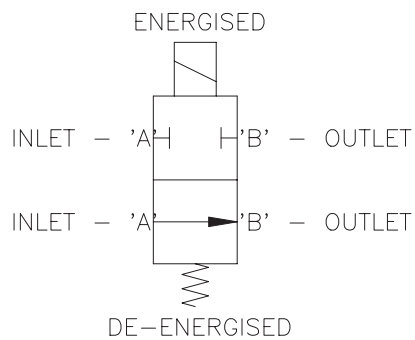

VALVE SYMBOL FOR
ENERGISE TO CLOSE
(NORMALLY OPEN)
20 BAR MAX WORKING
PRESSURE

Ordering Information

Model	Operating Pressure	Port Config.		Operation	Process Connection	Seat/Seal Materials	Conduit Connection	Voltage	Body/Trim Materials
Y1	2	1	2	A	A3	H	1	B	S
ICO4S	0-20 Barg (290 psi)	2/2 ENG. TO OPEN	2/2 ENG. TO CLOSE	Automatic	A3	H	1	A 18/33V DC	S 316 SS / 316 SS
					1/2" NPT	High Nitrile	M20x1.5	B 24V DC	M Alu Brnz / Alu Brnz
					E3	V	2	C 50V DC	
					1/2" BSPP	Viton®	1/2" NPT	D 110V DC	3 Titanium / Titanium
								E 125V DC	
								G 25V AC	
								J 110V AC	
			M 240V AC						

1/2" 3/2

Ordering Example

Y1	2	1	A	E3	V	1	J	M
ICO4S	0-20 Barg (290 psi)	2/2 E/O	Auto	1/2" BSPP	VITON®	M20 x 1.5	110V AC	Alu Brnz / Alu Brnz

Power Consumption (At Nominal)

DC Standard		AC Standard	
18 / 33V DC (24V DC)	CALL	25V AC	13.3 W
24V DC	15.1 W	110V AC	14.2 W
50V DC	16.6 W	240V AC	17.9 W
110V DC	15.5 W		
125V DC	15.1 W		

Profile and Dimensions mm

2/2 ENERGISE TO OPEN

- Valve is energised
Valve 'changes over'

Flow occurs between ports 'A' & 'B'
- Valve is de-energised
Valve resets

No flow occurs between ports 'A' & 'B'

2/2 ENERGISE TO CLOSE

- Valve is energised
Valve 'changes over'

No flow occurs between ports 'A' & 'B'
- Valve is de-energised
Valve resets

Flow occurs between ports 'A' & 'B'

Thompson Valves reserves the right to amend product specifications or designs without notice. Information is given in good faith and no liability can be accepted for error or omission. Viton® is a registered trademark of DuPont Performance Elastomers.